

GL Net Surveyor - GL's Network Surveillance System

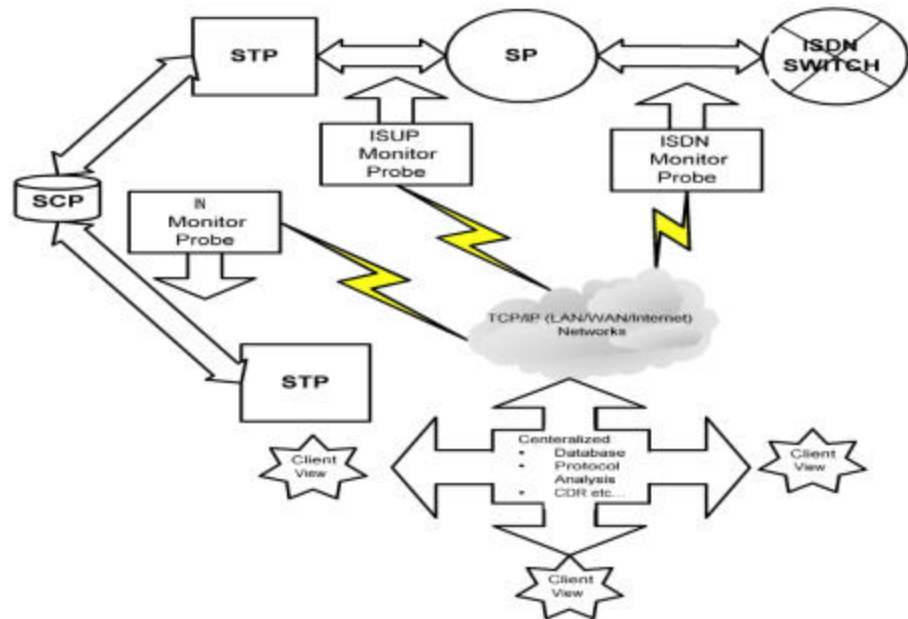

Introduction: In today's networks, surveillance of network characteristics is becoming more important than ever before. Performance monitoring, security, fraud detection, alarm monitoring, billing verification, remote protocol analysis, failure prediction, and traffic engineering are some aspects that need to be monitored continuously. A network operator, service provider, or equipment manufacturer must have the means to perform the above surveillance tasks cost-effectively, remotely, automatically, and non-intrusively. Fortunately, the network backbone contains a wealth of information that can be monitored and collected to support these activities.

GL Communications has developed a system, called the **GL Net Surveyor**, which uses an open three tier distributed architecture driven by non-intrusive hardware probes, intelligent software, and a database engine. The architecture is shown above and consists of a scalable and flexible system, so the user can use it for multiple sites and various applications. T1/E1/T3 Probes are deployed in the field to monitor various protocols and conditions which are then collected at a central site into a database. Data records are stored into a relational database (Oracle, DB2, Sybase, Microsoft Access, etc.) using ODBC. Various Client applications can be written (in VB, Power Builder, etc.) to interrogate database records and provide a user friendly interface for query and display.

Architecture and Key Features:

- T1/E1/T3 Probes non-intrusively monitor physical lines of the network
- The probes connect via TCP/IP to ODBC compliant real-time database loader
- Only precise and filtered data (user selectable) is collected into the centralized database
- Client Users can log into the central system locally/remotely to view the collected data
- Users view the collected data for different purposes like Troubleshooting, Call Detailed Records, Traffic Monitoring, Quality of Service, etc.
- Modular and distributed architecture is capable of theoretically "infinite capacity"

Typical Applications:

- Call Detail Records, Fraud Detection and Location, Remote Protocol Analysis and Troubleshooting, Real-Time Signaling Monitor, Traffic Optimization Engineering, Statistics
- Revenue and Billing Verification, Alarm Monitoring, Intrusive Testing
- Quality of Service Measurements, Call Trace and Recording

Conventional Protocols:

- CAS (R1- now, R2 - future), SS7 ISUP/TUP (Different Variants)
- ISDN (4ESS, 5ESS, ITU, ETSI, BELLCORE, QSIG)
- GR303, V5.X, INAP CS1 & CS2, INAP+, SS7 ANSI AIN

GL Communications Inc.

207A Perry Parkway Suite One, Gaithersburg, MD 20877 • (V) 301-670-4784 (F) 301-670-9187

Web Page Address: <http://www.gl.com> • E-Mail Address: gl-info@gl.com

Call Detail Records

Fraud Detection / Location

Remote Protocol Analysis and Trouble-shooting

Real-Time Signaling Monitor

Traffic Optimization / Engineering / Statistics

Revenue Billing Verification

Alarm Monitoring

Quality of Service Measurements

Call Trace and Recording

Protocols for Mobile Networks:

- IS41-C, GSM A and A-bis Interface, GPRS Gb, ETSI MAP

T1/E1/T3 Probe Interface Characteristics

- Single or Dual T1/E1 Cards with Multiple Cards per PC – up to 4 Dual PCI T1/E1 Cards per PC
- Multiple Link Sets Per T1/E1 (thru Digital Cross Connect Grooming) – multiple 64 kbps signaling channels per T1/E1 can be monitored simultaneously by grooming through a digital cross-connect – see diagram below
- T1/E1 Cards can also be connected non-intrusively in Monitor or Bridge Modes, or alternatively the data can be looped through the cards

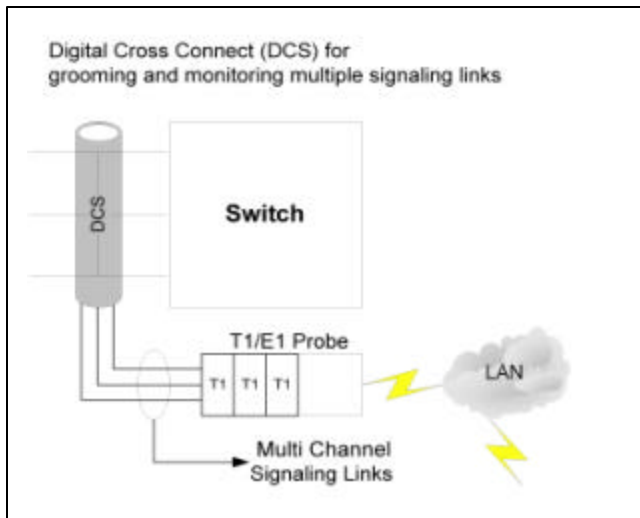

Typical Client Configurations

- Shown below is a typical client configured for protocol analysis monitoring of GR 303, ISDN, SS7, and Lap D from four different T1/E1 Probes in the network. Data is shown being captured in real time and displayed at a central site.
- The probes are accessible thru IP addresses and programmable for capturing only the data required for database storage.
- At the Client location database records can be accessed, processed, and displayed in a variety of ways. Also shown below is an SQL Client requesting that all calls to 555**** be displayed as soon as they occur in the network.

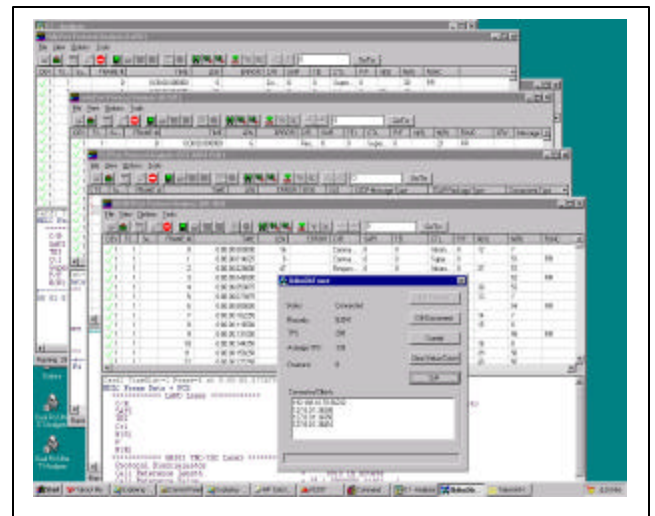

Single / Dual PCI T1/E1 Cards

Shown below are single and Dual PCI T1/E1 Cards used at Probe location points in the network.

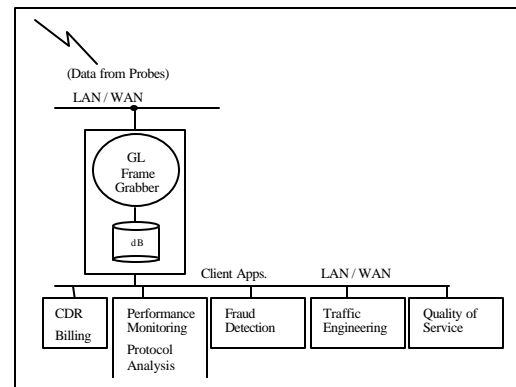
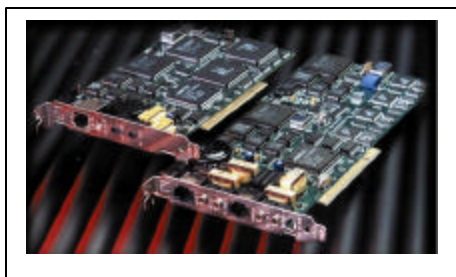

Buyers Guide

- xx060a Basic Windows Client Server Scripted Control Software
- xx060b w/transmit and receive file capability
- xx060c w/dtmf/mf/mfc-r2 capability
- xx060d w/dsp capability
- xx060e w/hdlc encode/decode capability
- xx060f w/centralized database engine and client

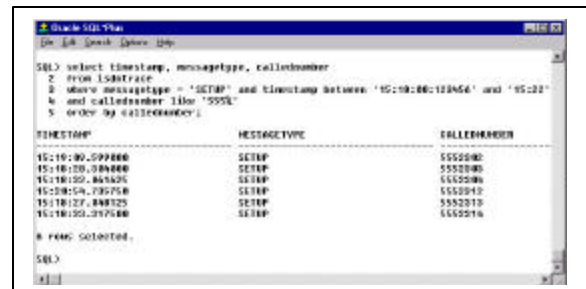

GL Communications Inc.

207A Perry Parkway, Suite One, Gaithersburg, MD 20877 • (V) 301-670-4784 (F) 301-670-9187

Web Page Address: <http://www.gl.com> • E-Mail Address: gl-info@gl.com